

CHEETAH® KNEE



The Cheetah Knee is a lightweight polycentric knee with 3-phase hydraulic swing control, specifically designed for rapid flexion and extension for running and sprinting. The polycentric design offers good stability in stance, allowing for controlled deceleration enabling users to participate in a wide range of sports activities. Although not specifically designed for walking, Cheetah Knee's 4-bar geometry makes it possible to walk and easily transition from walking to jogging and/or running.

- Polycentric knee, designed for high activity such as jogging, running and sprinting
- 4-bar geometry for increased stability in stance
- Hydraulic swing control to support rapid flexion and extension
- Soft extension bumper
- Short knee center to top distance, useful for long transfemoral limbs or knee disarticulation
- Male pyramid distal connection for easy alignment



Patient Profile:	
Amputation Level:	Transfemoral and Knee Disarticulation
Impact Level:	Moderate to Extreme
Maximum Patient Weight:	100 kg (220 lbs)

Product Information:	
Build Height:	108mm (4.3")
Weight of Knee:	0.62 kg (1.37 lbs)
Flexion:	110°

CLEARANCE

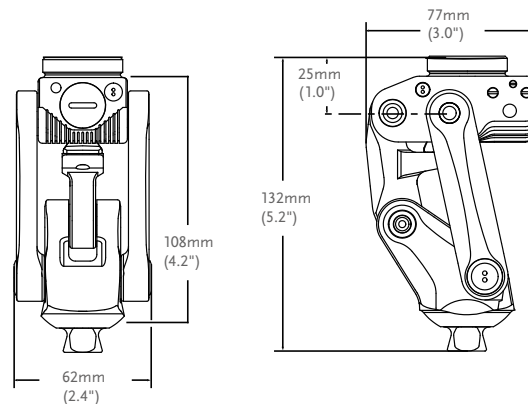

KITS

Part#	Description
CKN10000	Cheetah Knee

CHEETAH® KNEE

COMPONENTS

TOTAL KNEE ADAPTERS

Picture	Part#	Description	Material	Weight Limit		Weight	
1.	A-114040	4- Prong Socket Adapter	Stainless Steel	166kg	365lbs	158g	4oz
2.	A-122300	Euro 4-Hole Adapter	Aluminum	125kg	275lbs	70g	2.5oz
3.	A-834300	Male Pyramid Adapter	Stainless Steel	100kg	220lbs	111g	3.9oz
3.	A-835300	Male Pyramid Adapter	Titanium	166kg	365lbs	80g	2.8oz
4.	A-845300	Female Pyramid Adapter	Titanium	166kg	365lbs	85g	3oz

